

Type: **DILM32-10(230V50HZ,240V60HZ)**  
 Article No.: **277260**



Ordering information			
Rated operational current AC-3 400 V	$I_e$	A	32
Max. rating for three-phase motors, 50 – 60 Hz AC-3 230 V	$P$	kW	10
Max. rating for three-phase motors, 50 – 60 Hz AC-3 400 V	$P$	kW	15
Max. rating for three-phase motors, 50 – 60 Hz AC-3 690 V	$P$	kW	17
Max. rating for three-phase motors, 50 – 60 Hz AC-4 230 V	$P$	kW	4
Max. rating for three-phase motors, 50 – 60 Hz AC-4 400 V	$P$	kW	7
Max. rating for three-phase motors, 50 – 60 Hz AC-4 690 V	$P$	kW	10
Conventional thermal current $I_{th} = I_e$ AC-1 Open	$I_{th} = I_e$	A	40
For use with			DILM32-XHI.. DILA-XHI(V)..

General			
Standards			IEC/EN 60947, VDE 0660, UL, CSA
Lifespan, mechanical			
AC operated	Operations	$\times 10^6$	10
DC operated	Operations	$\times 10^6$	10
Operating frequency, mechanical			
AC operated	Operations/h		5000
DC operated	Operations/h		5000
Climatic proofing			Damp heat, constant, to IEC 60068-2-78 Damp heat, cyclical, to IEC 60068-2-30
Ambient temperature			

Open		°C	-25/60
Enclosed		°C	-25/40
Storage		°C	-40/80
Mechanical shock resistance (IEC/EN 60068-2-27)			
Half-sinusoidal shock, 20 ms			
Main contacts			
Make contact		g	10
Auxiliary contacts			
Make contact		g	7
Break contact		g	5
Protection type			IP00
Protection against direct contact when actuated from front (IEC 536)			Finger- and back-of-hand proof
Weight			
AC operated		kg	0,42
DC operated		kg	0,48
Terminal capacity Main cable			
Solid		mm <sup>2</sup>	1 × (0.75 – 16) 2 × (0.75 – 10)
Flexible with ferrule		mm <sup>2</sup>	1 × (0.75 – 16) 2 × (0.75 – 10)
Stranded		mm <sup>2</sup>	1 × 16
Solid or stranded		AWG	18 – 6
Anschlussschraube Hauptleiter			M5
Tightening torque		Nm	3
Terminal capacity Control circuit cables			
Solid		mm <sup>2</sup>	1 × (0.75 – 4) 1 × (0.75 – 4)
Flexible with ferrule		mm <sup>2</sup>	1 × (0.75 – 2.5) 2 × (0.75 – 2.5)
Solid or stranded		AWG	18 – 14
Anschlussschraube Hilfsleiter			M3.5
Tightening torque		Nm	1.2
Tool			
Main cable			
Pozidriv screwdriver		Size	2
Standard screwdriver		mm	0.8 × 5.5 1 × 6
Control circuit cables			
Pozidriv screwdriver		Size	2
Standard screwdriver		mm	0.8 × 5.5 1 × 6
Terminal capacity Control circuit cables			
Solid		mm <sup>2</sup>	0.75 – 2.5
Flexible		mm <sup>2</sup>	0.75 – 2.5
Flexible with ferrule		mm <sup>2</sup>	0.75 – 2.5
Solid or stranded		AWG	18 – 14

Tool			
Stripping length		mm	10
Screwdriver blade width		mm	3,5
<b>Main conducting paths</b>			
Rated impulse withstand voltage	$U_{imp}$	V AC	8000
Overvoltage category/pollution degree			III/3
Rated insulation voltage			
AC	$U_i$	V AC	690
Rated operational voltage	$U_e$	V AC	690
Safe isolation to VDE 0106 Part 101 and Part 101/A1			
between coil and contacts		V AC	440
between the contacts		V AC	440
Making capacity (cos $\phi$ to IEC/EN 60947) up to 690 V		A	384
Breaking capacity			
220/230 V		A	320
380/400 V		A	320
500 V		A	320
660/690 V		A	180
Component lifespan			
AC-3/AC-4			Tripping characteristics
Maximum operating frequency			
AC-1; 400 V	$I_e$	Ops/h	800
AC-3; 400 V	$I_e$	Ops/h	800
AC-4; 400 V	$I_e$	Ops/h	300
Short-circuit rating			
Short-circuit protection Maximum fuse			
Type "2" coordination			
400 V	gG/gL 500 V	A	63
690 V	gG/gL 690 V	A	35
Type "1" coordination			
400 V	gG/gL 500 V	A	125
690 V	gG/gL 690 V	A	63
<b>AC</b>			
AC-1 duty			
conv. therm. current 3-pole 50 – 60 Hz			
open			
at 40 °C	$I_{th}$	A	45
at 50 °C	$I_{th}$	A	43
at 55 °C	$I_{th}$	A	42
at 60 °C	$I_{th}$	A	40
Enclosed	$I_{th}$	A	36
Conventional free air thermal current, 1-pole			
open	$I_{th}$	A	85

Enclosed	$I_{th}$	A	80
AC-3 duty			
Rated operational current AC-3 open, 50 – 60 Hz, 3-pole			
220/230 V	$I_e$	A	32
240 V	$I_e$	A	32
380/400 V	$I_e$	A	32
415 V	$I_e$	A	32
440V	$I_e$	A	32
500 V	$I_e$	A	32
660/690 V	$I_e$	A	18
Motor rating			
220/230 V	$P$	kW	10
240V	$P$	kW	8,5
380/400 V	$P$	kW	15
415 V	$P$	kW	14,5
440 V	$P$	kW	15,5
500 V	$P$	kW	17,5
660/690 V	$P$	kW	17
AC-4 duty			
Rated operational current AC-4 open, 50 – 60 Hz, 3-pole			
220/230 V	$I_e$	A	15
240 V	$I_e$	A	15
380/400 V	$I_e$	A	15
415 V	$I_e$	A	15
440 V	$I_e$	A	15
500 V	$I_e$	A	15
660/690 V	$I_e$	A	12
Motor rating			
220/230 V	$P$	kW	4
240 V	$P$	kW	4,5
380/400 V	$P$	kW	7
415 V	$P$	kW	7,5
440 V	$P$	kW	8
500 V	$P$	kW	9
660/690 V	$P$	kW	10
<b>DC</b>			
of three-phase capacitors open			
DC-1 operation			
60 V	$I_e$	A	40
110 V	$I_e$	A	40
220 V	$I_e$	A	40
440 V	$I_e$	A	2,9
DC-3 operation			
60 V	$I_e$	A	40
110 V	$I_e$	A	40

220 V	$I_e$	A	25
440 V	$I_e$	A	0,6
DC-5 operation			
60 V	$I_e$	A	40
110 V	$I_e$	A	40
220 V	$I_e$	A	25
440 V	$I_e$	A	0,6
<b>Current heat loss (3-pole)</b>			
Current heat loss at $I_{th}$		W	12,1
Current heat loss at $I_e$ to AC-3/400 V		W	6,1
Impedance per pole		mΩ	2
<b>Magnet systems</b>			
Voltage tolerance			
AC operated			
AC operated	Pick-up	$\times U_c$	0,8 – 1,1
Drop-out voltage AC operated			
Drop-out voltage AC operated	Abfall	$\times U_c$	0,3 – 0,6
DC operated			
DC operated	Pick-up	$\times U_c$	0,7 – 1,2
DC operated			
DC operated	Abfall	$\times U_c$	0,15–0,6
Power consumption of the coil in a cold state and $1.0 \times U_c$			
50 Hz	Pick-up	VA	50
50 Hz	Pick-up	W	40
50 Hz	Sealing	VA	8
50 Hz	Sealing	W	2,4
60 Hz	Pick-up	VA	62
60 Hz	Pick-up	W	50
60 Hz	Sealing		9,1
60 Hz	Sealing	VA	2,7
50/60 Hz	Pick-up	VA	60 54
50/60 Hz	Pick-up	W	48 43
50/60 Hz	Sealing	VA	9,5 7,9
50/60 Hz	Sealing	W	2,8 2,4
DC operated	Pick-up	W	12 at 24 V
DC operated	Sealing	W	0.5 at 24 V
Duty factor		% DF	100
Switching times at 100 % $U_c$ (approximate values)			
Main contacts			
AC operated			
Closing delay		ms	25
Opening delay		ms	25

DC operated			
Closing delay		ms	60
Opening delay		ms	15
Arcing time		ms	10
<b>Electromagnetic compatibility (EMC)</b>			
Emitted interference			to EN 60947-1
Interference immunity			to EN 60947-1

### Mounting position, AC- and DC operated

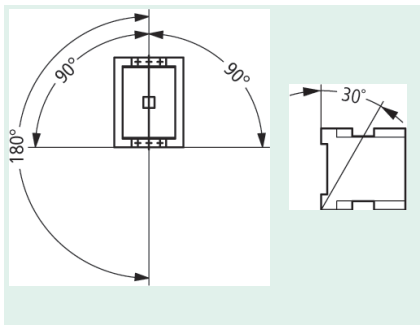

Moeller GmbH, Hein-Moeller-Str. 7-11, D-53115 Bonn  
 E-Mail: [catalog@moeller.net](mailto:catalog@moeller.net), Internet: [www.moeller.net](http://www.moeller.net), <http://catalog.moeller.net>  
 Copyright 2005 by Moeller GmbH. Subject to modifications. HPL-C2005GB-INT V3.0